

HYDRAULIC / ELECTRIC
ECOFRIDGE TOPLINE 16



TOPLINE 16 IS A HYDRAULIC AND ELECTRIC POWERED UNIT with extremely reliable properties. This efficient and fuel-saving unit has carefully selected components for optimal performance.



Topline 16 can be supplied in several designs with different functions and is equipped with the Hultsteins HUA control system. The unit is mounted externally on the front wall.

ECOFRIDGE

Topline 16

- ▶ Hydraulic constant flow pump delivers full power regardless of speed
- ▶ Fuel savings of up to 60%
- ▶ Reduced CO₂, NO_x & PM emissions
- ▶ Lower service costs
- ▶ Mounted on the body above the cab
- ▶ Mains connection 400 V
- ▶ HUA control system

FUNCTION

TOPLINE 16 IS POWERED BY A HYDRAULIC CONSTANT FLOW PUMP which is mounted directly on the truck's PTO. This unit provides constant power whatever the engine speed. The unit can also be connected to the mains.

The Smart Start feature allows the refrigeration system to start and stop the truck engine when parked. The unit can also be connected to the mains. Heat is provided by electric and water heaters. The unit can be equipped with an extra evaporator.

Topline 16 offers major fuel savings, reduced CO₂ emissions and lower service costs.



TECHNICAL SPECIFICATIONS

Model	Refrigeration capacity*			Electric power*			Standard heat	Extra heat Water	Multizone	Weight
	Box temp 0°C	Box temp -10°C	Box temp -20°C	Box temp 0°C	Box temp -10°C	Box temp -20°C				
Topline 16	11 500 W	9 300 W	6 400 W	8 700 W	7 900 W	6 200 W	Yes	No	Option	515 kg

*Refrigeration capacity specified at +30°C ambient temperature.

DIMENSIONS

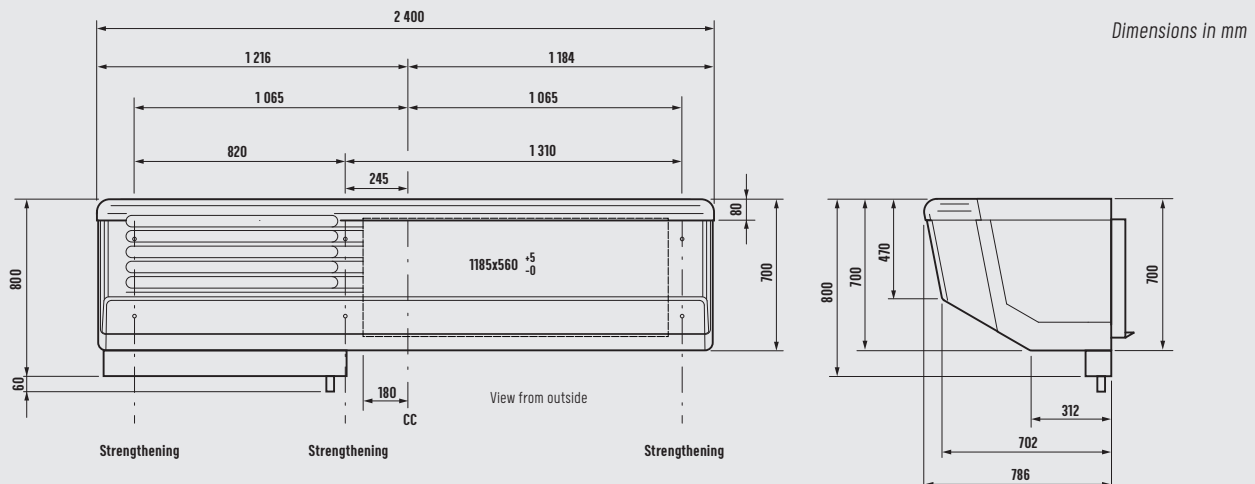

HULTSTEINS

Hultsteins UK | Unit 3, Guinness Park Farm, Leigh Sinton, Worcestershire, England, WR13 5EQ | Tel 01886 886169 | hultsteins.com